

The Electronic Structure and Torsional Potentials in Ground and Excited States of Biphenyl, Fulvalene, and Related Compounds

Akira Imamura and Roald Hoffmann

Contribution from the Department of Chemistry, Cornell University, Ithaca, New York. Received April 3, 1968

Abstract: The electronic structure of biphenyl, fulvalene, and related molecules in ground and excited states is studied. To a π -electron SCF and SCF-CI calculation we couple an evaluation of the H-H repulsion to estimate torsional potential energy curves in ground and excited states. The changes in conformational preferences in excited states are easily predicted from a simple correlation diagram connecting planar and twisted molecules. Thus for two coupled q π -electron systems one expects planar ground states, possibly twisted excited states, for $q = 4n + 1$ or $4n + 3$; planar ground or excited states, possibly triplet or quintet ground states, for $q = 4n$; possibly twisted ground states and planar excited states for $q = 4n + 2$.

The molecule of biphenyl is planar or nearly so in the solid state,^{1,2} twisted some 40° around the central single bond in the vapor phase.³ The ground-state torsion is thus clearly a delicate balance of nonbonded repulsion and conjugation, and the ground-state rotational potential has attracted some theoretical attention.⁴⁻⁶ There have been a number of calculations directed toward explicating the spectrum of biphenyl.⁷⁻¹³ These calculations probe only the ground-state geometry, and generally good agreement with experiment is obtained for twist angles correlating well with the vapor-phase equilibrium geometry. That the inter-ring bond acquires some double-bond character in the lowest excited state of the molecule is an obvious conclusion from either a valence-bond¹⁴ or molecular-orbital¹⁵ viewpoint. The influence of this potential energy change on the position and intensity of electronic transitions has been ably discussed by Jaffé and Orchin.¹⁵ Recently, some stimulating experiments were reported by Wagner.¹⁶ From a study of the singlet-triplet absorption, its quenching, and the phosphorescence of biphenyl, it was concluded that in its lowest excited triplet biphenyl was planar, in contrast to its twisted ground-state equilibrium conformation.

In order to analyze this conformational change in biphenyl, we describe here some semiempirical self-consistent-field-configuration-interaction (SCF-CI) calculations on the molecule. For contrast with biphenyl, a molecule which as a result of a relatively minor steric interaction is twisted in the ground state but overcomes the steric disadvantage in the excited state, we chose for similarly detailed study a molecule planar in the ground state but tending less to planarity in its excited states, fulvalene. We also considered the interesting cases of dicyclobutadiene and dicyclopentylidene.

Method

To obtain a potential energy curve we superimpose on a Pariser-Parr-Pople SCF-CI π -electron calculation¹⁷ an evaluation of the nonbonded repulsion between ring hydrogens. The method and parameters of the SCF-CI calculation are the same here as those reported previously by us.¹⁸

Fischer-Hjalmar, in her previous ground-state study of biphenyl,⁶ tested four potential functions for the hydrogen-hydrogen interaction. They were all of the form

$$V(\text{H,H}) = A \exp(-r/B) - Cr^{-6} \quad (1)$$

and differed in the choice of constants. In eq 8 the distance is in Å units and the energy in kcal/mole. We also tested the four potential functions and obtained the most reasonable geometries (planar or near-planar excited state, twisted ground state) with the Bartell function,¹⁹ in which $A = 6590$, $B = 0.245$, and $C = 49.2$.

The H-H interaction energy, summed over all interactions, was simply added to the total π -electron energy to obtain the rotational potential energy curves in various excited states. The σ - π interaction which appears in nonplanar states was neglected, as well as the Jahn-Teller and pseudo-Jahn-Teller effects which are expected in some degenerate or near-degenerate rotated excited states. All the geometrical parameters of the molecule except the torsional angle around the

- (1) J. Trotter, *Acta Cryst.*, **14**, 1135 (1961); A. Hargreaves and S. H. Rizvi, *ibid.*, **15**, 365 (1962).
- (2) G. B. Robertson, *Nature*, **191**, 593 (1961).
- (3) A. Almendinger and O. Bastiansen, *Kgl. Danske Norske Videnskabs Selskab Skrifter*, No. 4 (1958); O. Bastiansen, *Acta Chem. Scand.* **4**, 926 (1950).
- (4) S. Samoilov and M. Dyatkina, *Zh. Fiz. Khim.*, **22**, 1294 (1948).
- (5) F. J. Adrian, *J. Chem. Phys.*, **28**, 608 (1958).
- (6) I. Fischer-Hjalmar, *Tetrahedron*, **19**, 1805 (1963).
- (7) A. London, *J. Chem. Phys.*, **13**, 393 (1945); E. T. Stewart, *J. Chem. Soc.*, 4016 (1958).
- (8) H. C. Longuet-Higgins and J. N. Murrell, *Proc. Phys. Soc. (London)*, **A68**, 601 (1955).
- (9) K. Iguchi, *J. Phys. Soc. Japan*, **12**, 1250 (1957).
- (10) H. Suzuki, *Bull. Chem. Soc. Japan*, **32**, 1340 (1959); H. Suzuki, "Electronic Absorption Spectra and Geometry of Organic Molecules," Academic Press, New York, N. Y., 1967, p 262.
- (11) Y. Gondo, *J. Chem. Phys.*, **41**, 3928 (1964).
- (12) R. Grinter, *Mol. Phys.*, **11**, 7 (1966).
- (13) A. Golebiewski and A. Parczewski, *Theoret. Chim. Acta*, **7**, 171 (1967).
- (14) G. N. Lewis and M. Kasha, *J. Am. Chem. Soc.*, **66**, 2100 (1944).
- (15) (a) H. H. Jaffé and M. Orchin, "Theory and Applications of Ultraviolet Spectroscopy," John Wiley and Sons, Inc., New York, N. Y., 1962, p 389; (b) H. H. Jaffé and M. Orchin, *J. Chem. Soc.*, 1078 (1960).
- (16) P. J. Wagner, *J. Am. Chem. Soc.*, **89**, 2820 (1967).

(17) L. Salem, "The Molecular Orbital Theory of Conjugated Systems," W. A. Benjamin Inc., New York, N. Y., 1966.

(18) R. Hoffmann, A. Imamura, and G. D. Zeiss, *J. Am. Chem. Soc.*, **89**, 5215 (1967).

(19) L. S. Bartell, *J. Chem. Phys.*, **32**, 827 (1960).

Table I. Observed and Calculated Excitation Energies and Oscillator Strengths in Biphenyl^a

Obsd excitation energy (ϵ)	Calculated energy (oscillator strength)		
	0°	45°	90°
	Singlets		
4.18 ^b	4.82 () (0.38)	5.12 (\perp) (0.001)	5.25 (f)
	4.99 (f)	5.15 (\perp) (0.0004)	5.59 (f)
5.22 ^c (16,500 ^b)	5.00 (\perp) (0.01)	5.22 () (0.19)	5.63 () (0.002)
	5.67 (f)	5.64 (f)	6.90 () (2.34)
6.43 ^d (45,000 ^b)	6.47 () (1.78)	6.57 () (1.95)	7.48 (\perp) (2.55)
	6.52 (f)	6.93 (\perp) (0.28)	
7.4 ^d (35,000 ^b)	7.30 (\perp) (1.70)	7.38 (\perp) (1.61)	
	Triplets		
3.27 ^e	3.30	3.60	3.82

^a Energy is in eV; || polarization parallel to long axis, \perp perpendicular to long axis; (f) means transition is dipole forbidden. All observed excitation energies measured in vapor phase, except for the longest wavelength one. ^b Reference 11. ^c Reference 10; also M. Nakamizo and Y. Kanda, *Spectrochim. Acta*, **19**, 1235 (1963). ^d E. P. Carr and H. Stuecklen, *J. Chem. Phys.*, **4**, 760 (1936). ^e Reference 16.

inter-ring bond were maintained the same in ground and excited states.

Biphenyl

To check the validity of our approximations, we first compare the excitation energies and oscillator strengths calculated from the closed shell SCF-CI method with experimental results. As was mentioned above, many authors have carried out such calculations and obtained good agreement with experiment. Our results for planar, 45° twisted and perpendicular biphenyl are presented in Table I.²⁰

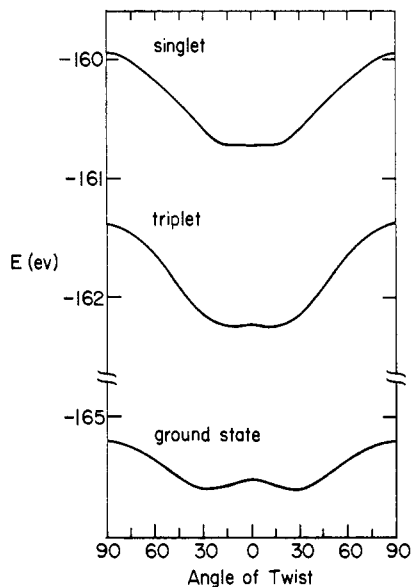

Figure 1. Total energy vs. angle of twist for the ground state and lowest singlet and triplet (symmetry SA) of biphenyl. Note the energy scale is interrupted.

It is clear that the agreement with experiment is good, especially for the 45° twisted molecule. This geometry is close to the experimentally observed ground-state equilibrium conformation of biphenyl.³ However, in our calculations the presence of a hidden band near 4.2 eV cannot be well explained.¹¹

(20) The idealized biphenyl geometry that was used had perfect hexagonal benzene rings, with C-C = 1.40 Å; the inter-ring bond was 1.48 Å. All singly excited configurations were included in the CI.

The approximations that enter into the π -electron part of the calculation thus appear to be reliable, and we can proceed to the computation of the torsional potential. The calculations of Fischer-Hjalmarsson⁶ on the ground-state torsion showed that with the proper choice of hydrogen-hydrogen interaction potential one could obtain good agreement (equilibrium angle of twisting of 30–40°) with the experimental geometry of biphenyl.

Figure 1 shows the calculated total energy curves (π -electron SCF-CI + hydrogen-hydrogen interaction) of the ground state and lowest singlet and triplet excited states. Figure 2 shows the results of an extended

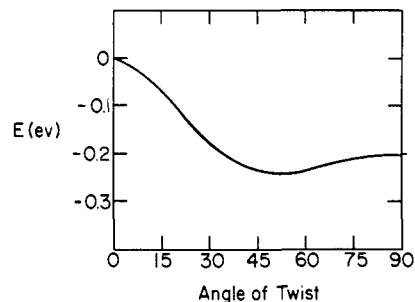

Figure 2. Extended Hückel energy vs. angle of twist for biphenyl. The energy zero has been arbitrarily assigned to the planar conformation.

Hückel calculation²¹ on the ground state of biphenyl. It should be noted that the extended Hückel calculations do not incorporate electron interaction and thus do not produce a singlet-triplet splitting.

The use of the Bartell H-H interaction function leads to a slightly twisted ground-state biphenyl and to excited-state curves with shallow planar or near-planar minima. A qualitatively similar geometry for ground and excited states is obtained from the extended Hückel calculation.

Why is biphenyl planar or nearly planar in its lowest excited states? We have assumed that the H-H interaction is the same in all states, and so the excited state preference is a direct consequence of the lesser curvature of π -electron energy. Figure 3 shows the π -electron energy (SCF-CI, all singly excited configurations)

(21) R. Hoffmann, *J. Chem. Phys.*, **39**, 1397 (1963), and subsequent papers. Here we use the same parameters, except for a H 1s exponent of 1.3.

curves of the group of lower singlets and triplets of biphenyl. The relation between curvature and symmetry is readily explained on the basis of a correlation diagram connecting the levels of a 90° twisted biphenyl with those of a planar molecule.²²

The energy levels of an isolated benzene ring are most familiar. They are reproduced below, classified according to their symmetry or antisymmetry with respect to a plane which will contain the long biphenyl axis.

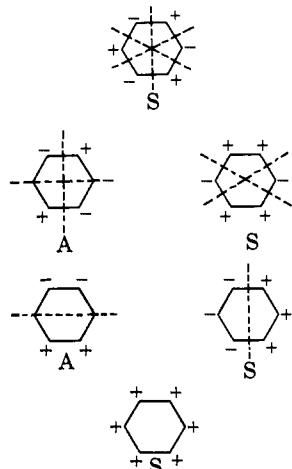

In a planar biphenyl each of these orbitals will combine with a corresponding orbital of the other phenyl

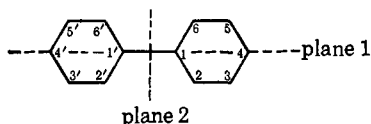

ring to give two molecular orbitals, one symmetric, the other antisymmetric, with respect to plane 2. Four possible symmetries arise.

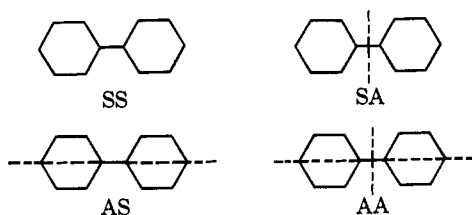

It is clear that, of the two combinations arising from an S orbital, SS will be stabilized considerably, since it is 1-1' bonding, whereas SA will be destabilized, since it is 1-1' antibonding.

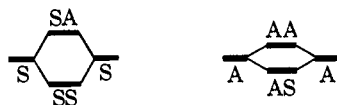

On the other hand, the two orbitals arising from an A level will not be split by much, since, as a consequence of antisymmetry with respect to plane 1, those molecular orbitals have no contribution from atomic orbitals at carbons 1 and 1'. The splitting which puts AS at slightly lower energy than AA arises from long-range interactions such as 2-2'.

(22) This correlation diagram has also been constructed by Jaffé and Orchin, ref 15a, p 401.

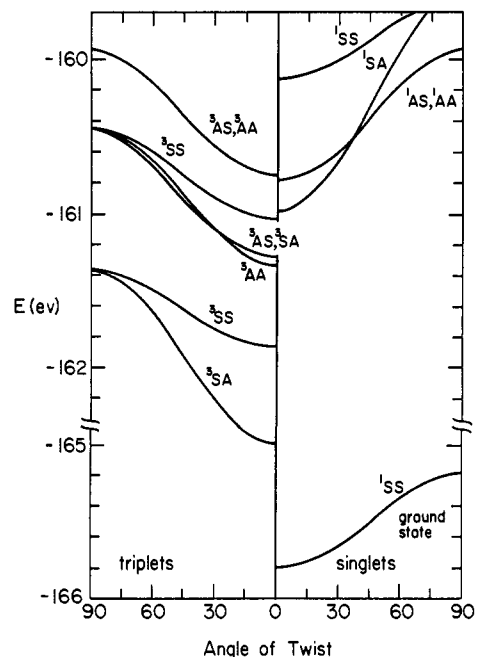
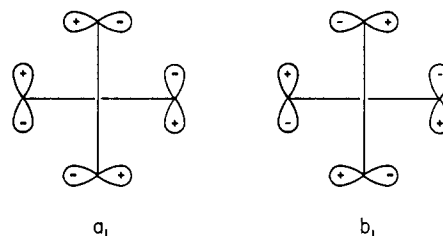

Figure 3. SCF-CI potential energy curves for biphenyl. The singlets are at right, the triplets at left. Some energy curves are very close to coinciding and have been drawn in the diagram as a single curve with two labels attached. Note the interrupted energy scale.

On the 90° twisted side there is generally little interaction, the system being essentially two noninteracting benzene rings. The little interaction there is of the spiro type,¹⁶ again dependent on long-range interactions. Even this minor interaction is straightforward to analyze. Orbitals of b_2 and b_3 symmetry (SA and SS in the planar form) merge into an e orbital in the D_{2d} geometry. a_1 and b_1 orbitals (formerly AA and AS) now split very slightly as a result of a spiroconjugation, with a_1 below b_1 .



The complete correlation diagram may now be drawn (Figure 4). We have gone in some detail through the above analysis to illustrate how simple ideas of bonding and overlap can predict the entire course of a correlation diagram. The actual energy levels confirm this analysis in every detail. Now that each level is characterized by a tendency to twist (SA), to resist twisting (SS), or to remain at the same energy irrespective of twisting (AS or AA), we can proceed to characterize the twisting proclivities of excited states.

The lowest energy multiplet of singlets arises from primarily the SA → SS (state symmetry SA), SA → AS (AA), SA → AA (AS), and SA → SA (SS) excitations. From the twisting properties of the levels, we would anticipate the SS state to resist twisting by as much energy as the ground state, the AA and AS states to resist twisting more, and the SA state to

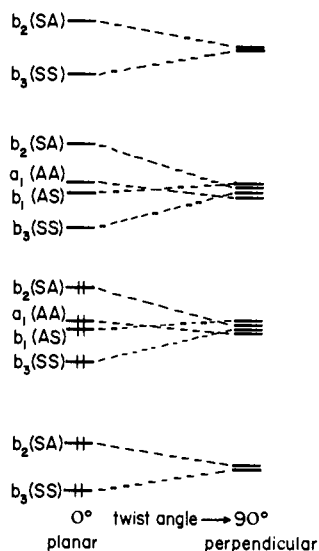

Figure 4. Correlation diagram relating the levels of planar and 90° twisted biphenyl. The energy levels are classified according to their symmetry in D_2 and their nodal properties in the planar geometry.

prefer planarity by still more. This is what is observed in Figure 3.

The ordering of the excited singlets differs somewhat from that of the triplets. Roughly speaking, the singlet-triplet splitting is twice the exchange integral (this is, of course, exactly true in the SCF method, but only approximately so when CI is included). In the assumption of zero differential overlap the splitting becomes

$$\Delta E_{S \rightarrow T(i \rightarrow j)} = 2K_{ij} = 2 \sum_{\tau} \sum_{\delta} c_{i\tau} c_{i\delta} c_{j\tau} c_{j\delta} (rr|ss) = 2 \sum_{\tau} (c_{i\tau} c_{j\tau})^2 (rr|rr) + \sum_{\tau} \sum_{\delta \neq \tau} c_{i\tau} c_{i\delta} c_{j\tau} c_{j\delta} (rr|ss) \quad (2)$$

In eq 2, the dominant term is the first. In order for this term to be large, the molecular orbitals i and j should have the same or related symmetry. In addition, the smaller the number of nodes passing through atoms in the product of the molecular orbitals i and j , the greater the splitting. On the basis of this argument it is expected that SS and SA states will have the largest singlet-triplet splittings, in agreement with Figure 3.

To strengthen our confidence in the excited-state properties, we also calculated the lowest triplet states by the open-shell method proposed by Roothaan.²³ There appear no significant differences in the rotational potentials. It is interesting to note, however, that the closed-shell SCF-CI method yields a lower energy than open-shell SCF.

Our calculations did not allow for geometry changes other than torsions in excited states. Such geometry changes clearly must take place and are quite predictable from the nodal structure of orbitals involved. Thus the SA biphenyl excited state is primarily a product of the SA \rightarrow SS excitation. These orbitals have the following appearance.

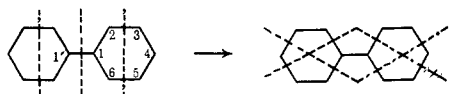

(23) C. C. J. Roothaan, *Rev. Mod. Phys.*, **32**, 179 (1960).

On excitation the 1-1' and 2-3 bonds are strengthened and the 1-2 and 3-4 bonds weakened. This is apparent in the calculated bond orders, and indicates the quinoid

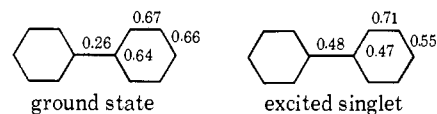

valence structure for the excited state

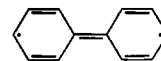

Fulvalene

The characteristic electronic features of nonalternant hydrocarbons such as fulvene, fulvalene, etc. have been extensively studied by Nakajima and coworkers.²⁴ In their studies they obtained good agreement with experiment on the excitation energies and intensities of the fulvalene spectrum. In our work we use precisely the same procedure as that described in the above section for biphenyl.

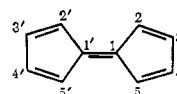

The ordering of fulvalene levels would be obtained from a simple Hückel calculation. We prefer the more instructive twofold constructions of Figure 5. The simplest analysis begins with the 90° twisted molecule. Neglecting the spiro interaction this is merely a system of two noninteracting cyclopentadienyl radicals, with each well-known energy level of the five-membered ring simply doubled. As twisting toward the planar form proceeds, by precisely the same argument as we presented for biphenyl, each "doublet" of the 90° twisted geometry will split into a stabilized b_3 (SS) and a destabilized b_2 (SA) level. Each "quartet" will yield a stabilized b_3 , a destabilized b_2 , and relatively unaffected a_1 and b_1 levels.

An alternative way to build up the fulvalene orbitals is to consider them as arising from the interaction of two butadienes and an ethylene. The interaction diagram is shown at left in Figure 5. It shows clearly the repulsion of levels of the same symmetry species.

The correlation diagram very simply rationalizes the preferred planar conformation of fulvalene. There are two occupied π levels which resist twisting (b_3) but only one which favors it (b_2). The correlation diagram also predicts the twisting tendencies of various excited states. The $a_1 \rightarrow b_2$ and $b_1 \rightarrow b_2$ singly excited configurations should resist twisting by less than the ground state and the $b_3 \rightarrow b_2$ excited configuration by still less.

The excitation energies and oscillator strengths we calculate²⁵ (closed-shell SCF, all singly excited configurations in CI) are presented in Table II, together with the results of Nakajima²⁴ and experimental observations.

The calculated values are not in good agreement with experiment for the planar form. A point of some

(24) T. Nakajima and S. Katagiri, *Bull. Chem. Soc. Japan*, **35**, 910 (1962).

(25) The following assumptions were made regarding the fulvalene geometry: all C=C = 1.35 Å; all C-C = 1.48 Å; C₂C₁C₃ angle = 108°; all other angles determined by assumed distances. All singly excited configurations were included in CI.

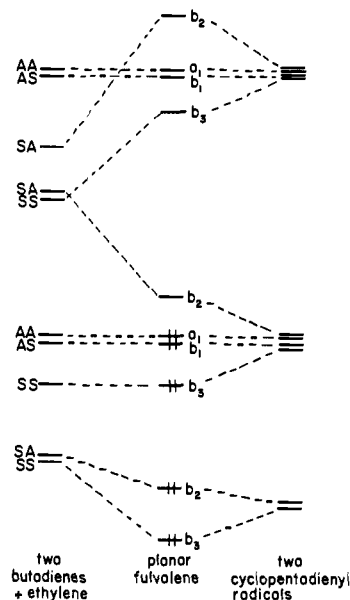

Figure 5. The energy levels of fulvalene. At right is a correlation diagram relating a 90° twisted fulvalene (two cyclopentadienyl radicals) to the planar molecule. At left is an interaction diagram deriving the planar fulvalene levels from those of an ethylene and two butadienes.

importance and one which we plan to check in the future is the question of the adequacy of the usual extent of CI, *i.e.*, all singly excited configurations, for non-alternant hydrocarbons such as fulvalene. We, like others,²⁶ have found the effects of complete CI dramatic on even simple alternant hydrocarbons such as butadiene, and we would expect the inclusion of multiply excited configurations to influence the level ordering of nonalternant hydrocarbons still more.

Table II. Observed and Calculated Excitation Energies and Oscillator Strengths in Fulvalene

Obsd	Energy (polarization ^b) (oscillator strength)	
	Calcd ^a	Nakajima, <i>et al.</i> ^c
2.98 (?)	3.41 (f)	2.38 (f)
3.93 (0.3)	3.47 (\perp) (0.05)	2.47 (\perp) (0.03)
	4.79 (\parallel) (1.18)	3.81 (\parallel) (1.2)
	6.32 (f)	
	6.44 (f)	

^a Twist angle = 0° . ^b Polarization is indicated with respect to the long axis. ^c Reference 24.

We calculate the torsional energy curves for fulvalene ground and excited states from the closed-shell SCF method. Since configuration interaction had little effect on the torsional potentials of biphenyl, we chose not to include it here. Also, with the assumed fulvalene geometry,²⁵ a C_3-C_2-H angle of 120° , and a C-H distance of 1.09 Å, one finds that the nearest H-H contact in the planar molecule is at 2.70 Å. This is just outside the repulsive region of the Bartell potential, and for this reason we omit consideration of the nonbonded interactions in the case of fulvalene. The results are depicted in Figure 6. Several interesting comparisons may be made with Figures 3 and 4 for biphenyl, keeping in mind the very

(26) *E.g.*, J. Koutecký, *J. Chem. Phys.*, **47**, 1501 (1967).

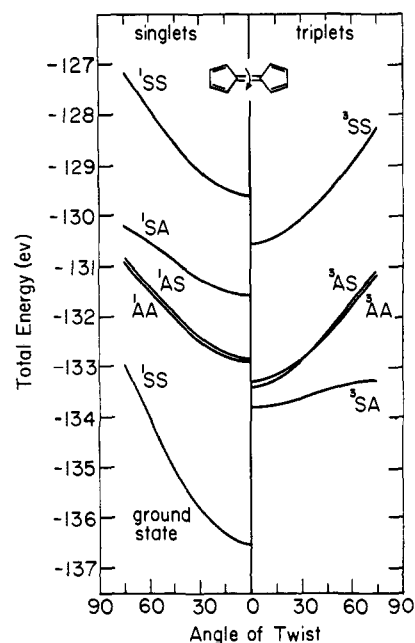

Figure 6. SCF-state energies for fulvalene as a function of twisting. Singlets are at left, triplets at right.

different energy scales for the two sets of figures. In the ground state of biphenyl, the π -electron energy favors a planar molecule by only 0.6 eV, an energy overcome by the H-H repulsions. As expected from the valence structure, fulvalene resists twisting by much more in its ground state, some 4.2 eV. In some biphenyl excited states there are greater preferences (up to 1.4 eV) for the planar form than in the ground state. In the excited states of fulvalene the stability of the planar geometry is generally reduced (relative to the ground state), but the torsional energies remain large. The greatest effect, as anticipated from the discussion of the correlation diagram, is for the SA(B_1) state arising from the $b_3 \rightarrow b_2$ excitation. 2,2'-Substituted fulvalenes would be expected to be nonplanar in the 3B_1 state. It is interesting to compare the effect of going from ground to excited state on the torsional potential in our present cases of fulvalene and biphenyl with the simple case of ethylene: in ethylene excited states the torsional potential clearly reverses;^{27,28} the excited state prefers to be twisted 90° from planarity. In biphenyl and fulvalene the π bonding which causes planarity, or its uncoupling, is diluted by the molecular orbitals involved in the excitation being delocalized over a larger number of atoms. We have noted this effect previously in equilibrium geometry changes in excited states of polyenes: butadiene twists around one double bond, hexatriene twists around the central bond, and octatetraene and higher polyenes remain planar, though all torsional barriers are lowered.²⁹

It is also interesting to point out again that the presence (SA) or absence (AS,AA) of a significant singlet-triplet splitting in different symmetry excited states of molecules like biphenyl and fulvalene is predictable on the basis of the nodal structure of the or-

(27) R. S. Mulliken and C. C. J. Roothaan, *Chem. Rev.*, **41**, 219 (1947).

(28) An excellent discussion is given in R. McDiarmid and E. Charney, *J. Chem. Phys.*, **47**, 1517 (1967).

(29) R. Hoffmann, *Tetrahedron*, **22**, 521 (1966).

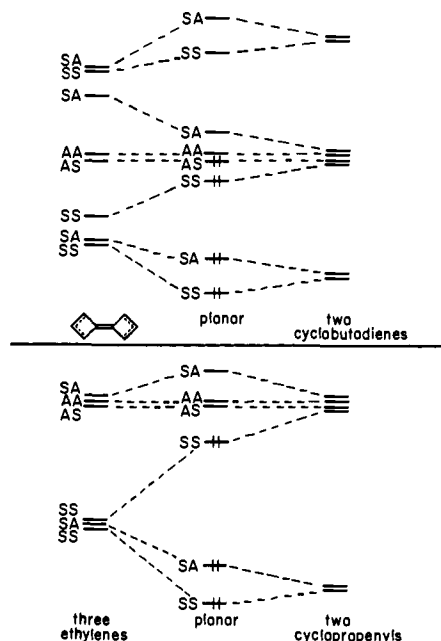
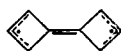

Figure 7. The energy levels of dicyclobutadiene and dicyclopropenylidene. At right are correlation diagrams relating the levels of a 90° twisted molecule to those of the planar geometry. At left are interaction diagrams showing the construction of the planar from energy levels from noninteracting components.

bitals. Still another interesting observation is the crossing of the twisted ground-state singlet surface with the excited triplet curve for fulvalene. This is highly reminiscent of a similar phenomenon calculated for ethylene.^{27, 28}

Dicyclobutadiene and Dicyclopropenylidene

The first-named of these is very much a hypothetical molecule. Its electronic structure does present some interesting problems. The level ordering in both molecules is easily derived by the two approaches we have illustrated: a correlation diagram from a 90° twisted system or an interaction diagram from some simpler components. In the case of dicyclobutadiene the components may be taken as two allyl radicals and a double bond. The level schemes are shown in Figure 7.



There are several direct implications of the dicyclobutadiene correlation diagram. (1) The AA and AS levels are virtually degenerate and so the ground state of the molecule should be a triplet arising from the $(AS)^1(AA)^1$ configuration. Perhaps even the quintet arising from $(SS)^1(AS)^1(AA)^1(SA)^1$ is competitive. (2) The molecule in its lowest singlet or triplet should definitely prefer to be planar, by a torsional energy as great as fulvalene. This conclusion follows from the fact that there are two SS levels favoring planarity and only one SA level preferring twisting. The tendency to planarity in two π systems coupled by a formal single bond was unusual but, as will be seen below, was confirmed by the computations. (3) All the lower singlets and triplets are anticipated to have the same twisting tendencies.

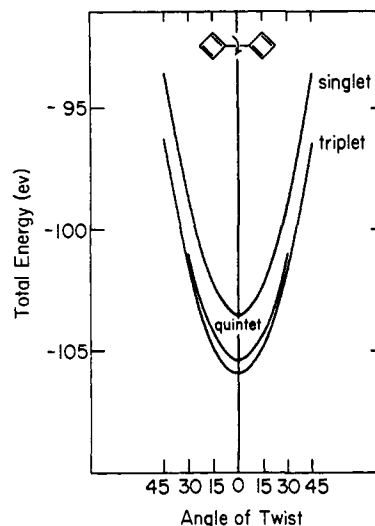

Figure 8. Torsional potential of the lowest singlet, triplet, and quintet states of dicyclobutadiene.

Figure 8 shows the potential energy curves of the lowest singlet, triplet, and quintet. The singlet curve is obtained from a closed-shell calculation; the others are from an open shell. The triplet state is lowest, but the quintet is not far above it. It should, however, be noted that complete CI will no doubt stabilize the singlet curve since doubly excited configurations are very important in nearly degenerate systems. All the lower singlets and triplets of dicyclobutadiene show the same preference for a planar geometry as the states shown in Figure 8. This tendency is remarkable. The valence structure which puts a double bond at the ring junction must describe the system well.

The ground and lower excited states of dicyclopropenylidene are shown in Figure 9. The torsional behavior is not interesting, but the spectral predictions for this very strained molecule are remarkable. An allowed singlet transition comes at 2.6 eV, and the lowest triplet is only 1.7 eV above the ground state. These are remarkably low energies for what is essentially a conjugated triene, but in view of our relative lack of success in calculating the fulvalene spectrum they should be treated with skepticism.

General Use of the Correlation Diagram

The essential features of the correlation diagram we drew for bicyclopropenylidene will be trivially modified for bicycloheptatrienyl (heptafulvalene). It is easy to derive the following general rules for the torsional behavior of two coupled π -electron systems, each with q π electrons

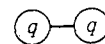

(1) $q = 4n + 1$. The essential part of the correlation diagram is shown below. The ground state is planar. Excited states reduce the tendency to planarity and with bulky substituents may twist.

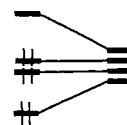

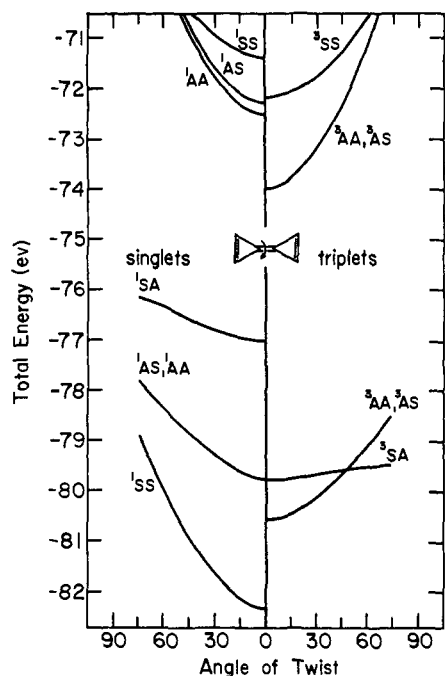
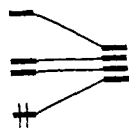

Figure 9. Total energy as a function of twist angle for the lowest singlets (left) and triplets (right) of dicyclopropenylidene. Double labels imply two energy curves nearly coincident.

(2) $q = 4n + 3$. The ground state is planar. Ex-



cited states reduce preference for planarity and may twist.

(3) $q = 4n$. The ground state is planar and likely

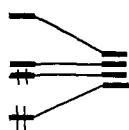

to be a triplet (or quintet). Conformational preferences in ground and lower excited states remain the same.

(4) $q = 4n + 2$. The ground-state π energy is

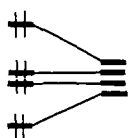

indifferent to twisting and so steric forces may lead to an equilibrium twisted conformation as for biphenyl. Lower excited states show greater tendency to planarity.

This use of correlation diagrams can be extended to other series of molecules. Consider the correlation diagrams of Figure 10 for the interaction of two allylic systems with q electrons, illustrated for bialllyl and bipentadienyl. The antisymmetric allylic orbitals are coupled only by a spiro interaction¹⁸ but symmetric

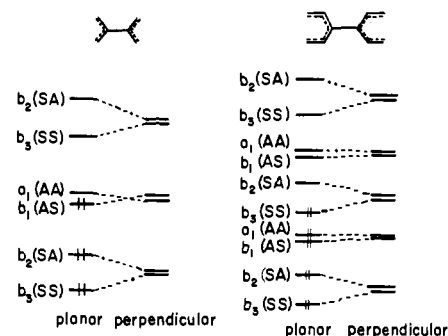

Figure 10. Correlation diagrams for bialllyl and bipentadienyl.

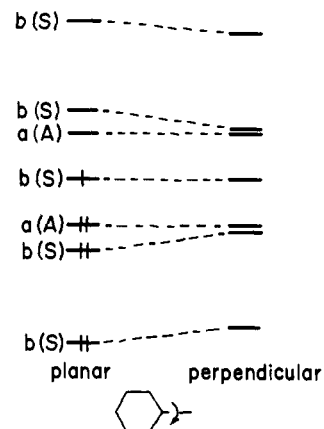

Figure 11. Correlation diagram for twisting benzyl.

ones by the much stronger direct interaction. Thus for bialllyl, or any system with $q = 4n + 3$, there is a delicate balance between singlet and triplet ground states. For $q = 4n + 1$, the nonbonding orbital splitting is large and the molecule is clearly a singlet ground state (*i.e.*, bipentadienyl becomes 3,4-divinylhexatriene). The $q = 4n + 1$ systems should have planar ground states and twisted excited states, but the conformational preference of the $q = 4n + 3$ diradicals should not change in its lowest energy states. The electronic structure of bialllyl is of considerable interest, and extensive calculations on this molecule were carried out in our laboratory.³⁰

The interaction of two π -electron systems with unequal numbers of electrons may be analyzed in a parallel manner. Consider for instance the correlation diagram relating the energy levels of a twisted benzyl system with those of a planar one (Figure 11). As one twists from perpendicular to planar, the methyl p orbital begins to interact with phenyl π orbitals of similar symmetry. The correlation diagram implies that ground and excited states of benzyl radical should have similar torsional preferences. We plan to report on the benzyl system at a later time.

Acknowledgments. We are grateful to the National Science Foundation, the National Institutes of Health, the Chevron Research Company, and the Sloan Foundation for research support.

(30) R. Hoffmann, B. G. Odell, and A. Imamura, unpublished work.